

Compact 80C



The Compact Solution



EcoClean

Compact 80C

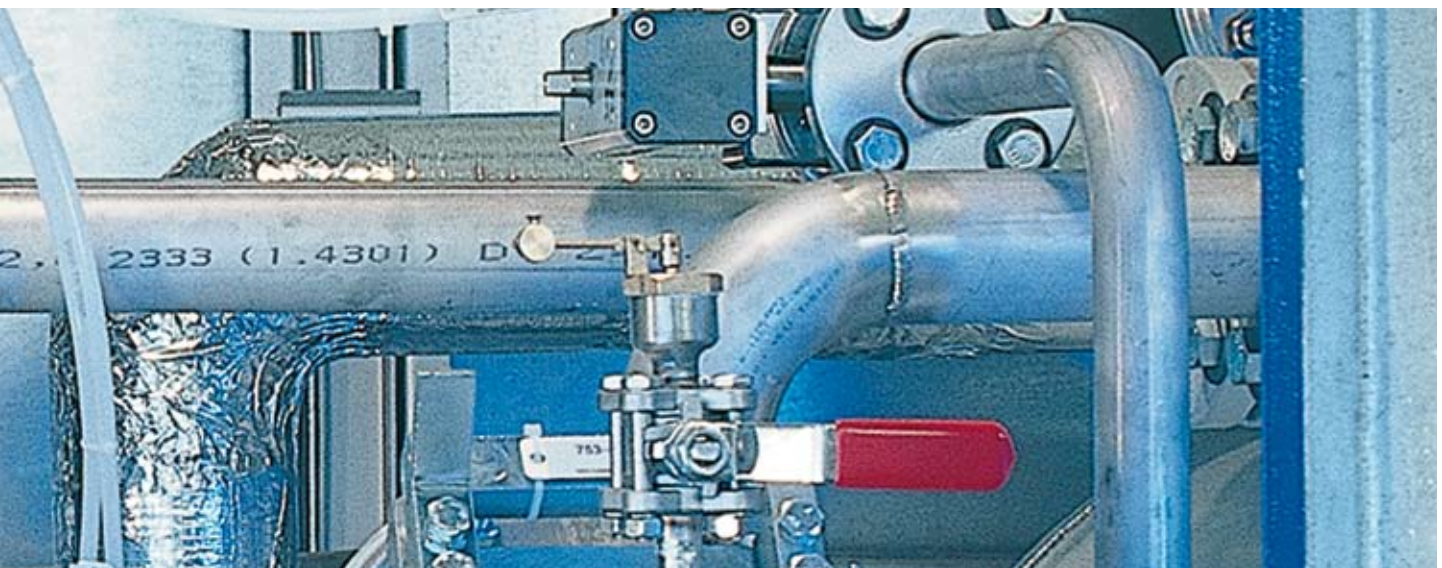

The Compact Solution

As highly effective cleaning media non-halogenated hydrocarbons allow safe and economical use of solvents for removing oils, greases, emulsions and swarf between or after manufacturing processes.

Both small factories with comparatively low production capacities and large factories with decentralised cleaning stations benefit from the sophisticated technology of the Compact 80C. Many different process variants using hot and/or cold immersion with down-line vapour degreasing are ideal for meeting the requirements expected of modern manufacturing processes with regard to quality and functionality.

Removal of large quantities of oil or swarf from mass-produced parts or particles of dirt with a defined size in fine cleaning can be achieved by selecting the appropriate filtering system and other application-dependent optional extras.

Equipment and Process

- Cleaning and drying process in an enclosed working chamber
- Circulation filtration
- Injection flood washing
- Emulsion separation
- Manual or automatic feed of the working chamber from the front
- Automatic locking of working chamber door
- Multiple monitoring of safety-relevant temperatures and pressures in the tanks
- Rotational and swivel movement to assist cleaning and drying process
- Continuous solvent treatment by vacuum distillation
- Continuous separation of low boiling substances and water
- Siemens S7 PLC control for individual programming of the process sequences
- Error diagnosis via plain text display on operator control panel (Siemens OP17)
- Minimised energy input due to heat recovery
- Large maintenance and cleaning openings in the tanks
- Closed system housing with maintenance doors for optimum access

Optional Extras

- second and third flood tanks for precision cleaning and conservation
- Fine filtration by cartridge filter
- Ultrasonic device
- Automatic feed
- Automatic basket lid placement
- Continuous oil discharge
- Modem
- Visualization



Advantages

- Sophisticated, redundant safety equipment for using solvents with a flash point > 55°C
- Operation almost totally emission free, environmentally friendly process
- Selectable water or air cooling
- Vacuum distillation for optimal solvent preparation
- Double solvent filtration during filling and emptying of working chamber

Compact 80C

Technical Data

Outside Dimensions of the System

Width	approx. 3.700 mm (145.6")
Depth	approx. 1.600 mm (63")
Depth with manual feeding	approx. 2.350 mm (92.5")
Height	approx. 3.340 mm (131.5")
Feed height	approx. 850 mm (33.5")

Basket

Length	approx. 530 mm (21")
Width	approx. 320 mm (12.6")
Height max.	approx. 200 mm (7.9")
Batch weight max.	75 kg (165 lb.)
Throughput depending on work sequence and treatment time required	approx. 12 batches/h

Connected Load 3x400V/50 Hz (3x480V/60 Hz)

Standard System

Motor power	approx. 13 kW
Heating power	approx. 9 kW
Total load	approx. 22 kW

Solvents which can be used

Aliphatic and naphthenised hydrocarbons, flash point > 55°C

Capacity of Standard System

With 1 flood tank	approx. 350 l (92 gal.)
Distillation unit	approx. 170 l (45 gal.)

www.durr-ecoclean.com

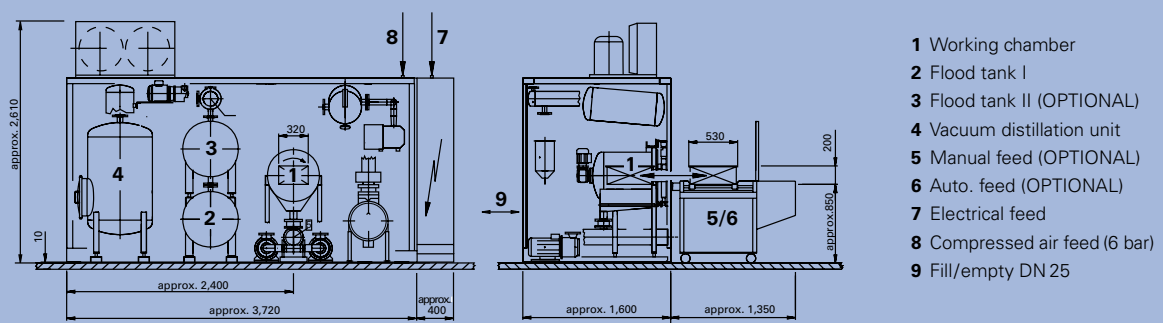

- 1 Working chamber
- 2 Flood tank I
- 3 Flood tank II (OPTIONAL)
- 4 Vacuum distillation unit
- 5 Manual feed (OPTIONAL)
- 6 Auto. feed (OPTIONAL)
- 7 Electrical feed
- 8 Compressed air feed (6 bar)
- 9 Fill/empty DN 25